



**One of the best dividable floor stand on wheels for flat panels up to 60 Kg.**

Free standing, dividable and movable floor stand for flat screens. The floor stand is supplied with high quality swivel/break wheels. The quick release feature allows you to install the floor stand and screen on any location without tools.

The floor stand consists of a strong and solid vertical column, supplied with a wide access hatch on the back for power, audio and data cables.

The presentation height of the flat panel is adjustable. This floor stand is suitable for flat panels with a maximum screen size of approx. 65 inch, in landscape or portrait orientation.

- ▲ **High quality swivel/break wheels**
- ▲ **No tools required for installation**
- ▲ **Integrated yet easily accessible cable channel**
- ▲ **Suitable for all brands of flat panels**
- ▲ **Landscape and portrait orientation of the screen**

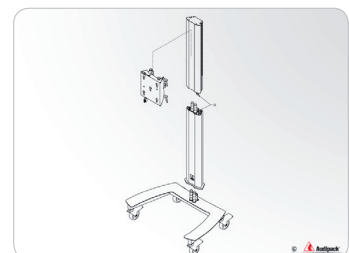



# Audipack®

It's great to have solutions...

# FACT SHEET

## 390905

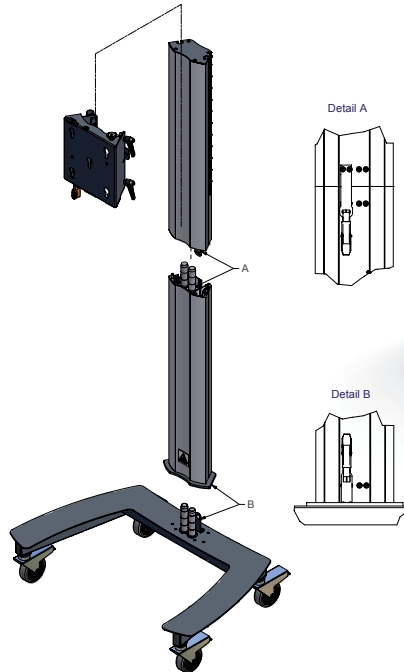
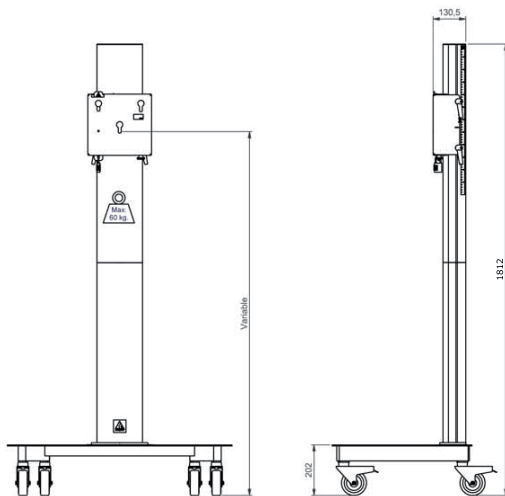
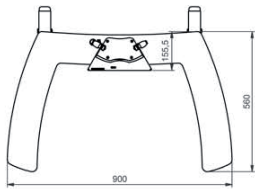

### Technical specifications

Dimensions in mm	W900 x D560 x H1812
Max. screen size	65 inch
Max. load	60 Kg
Mounting interface	L&S 5
Colour	Floor plate: Black, RAL 9005 Column: Anodised aluminium
Weight	51 Kg
Screen orientation	Landscape or Portrait

### Optional

- Mounting bracket (required for screen installation)  
*universal models and brand related models available*
- Laptop supports, 390915, 390916
- Laptop housings, 390937
- Equipment cabinets, EC-935, EC-936
- Mounting head for multiple screen installation, 390915
- Video conference mounting head, 390969, 390970
- Portrait/Landscape adapter, P3496
- Lock for protect the screen against theft, 230045, 230052