

FSW-T 150

Telescopic trolley stand for touch screens



1.

The FSW-T150 is an electric trolley stand suitable for (touch)monitors.
Use it only with locked wheels
Use it only on level floors



1.

The FSW-T150 comes as a package or as a pre-assembled model.

When un-assembled:

Install the column with corresponding holes and bolts to the wheel frame.
Install the top cabinet on top of the columns with corresponding bolts.
Install the power supply with the spacers in the inside of the top cabinet.
Guide the motor cables to the power supply and connect them.
Connect the activation switch and AC cable to the power supply.

2.

Above the power inlet a blanc connector panel is installed.
This can be used for custom installed connectors or i/o ports.

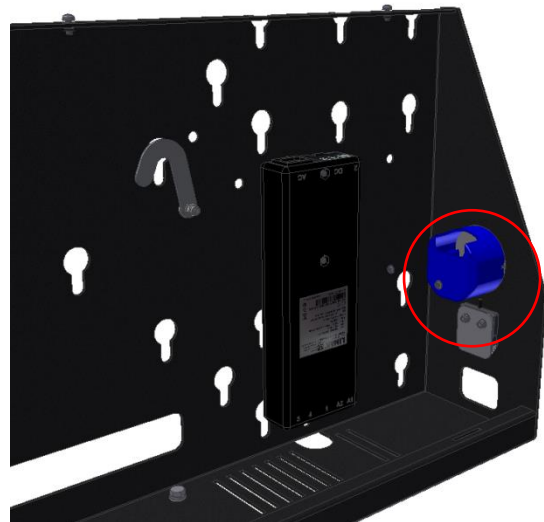

3.

The FSW-T150 has a build-on equipment cabinet that allows to install small equipment behind the screen such as computers and players.



4.
Install the screen with an Audipack universal mounting bracket when the screen is not equipped with a standard VESA mounting interface.
The FSW-T100 has standard the following mounting patterns:

- VESA 300x300
- VESA 400x200
- VESA 400x400
- VESA 600x200
- VESA 600x400
- VESA 800x400 (V8 model)
- Audipack L&S5 5 point mounting pattern.

Max. Load with VESA 150 Kg
Max. load with L&S5 85 Kg

* VESA mounting pattern may vary between models

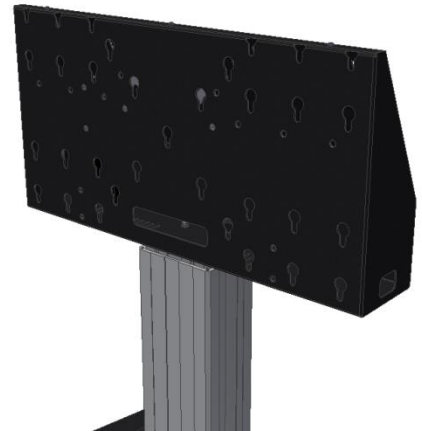

5.
Install the optional mounting cams in the rear of the screen and insert the screen in the mounting head of the FSW.
Secure it by locking the security hook on the inside.



6. Optional pen tray (FSW-PT1)

Install the optional pen tray by inserting the the 2 aluminium rods through the inside of the cabinet.
Slide in the square nuts and tighten them at the front to lock the desired height. Be sure to set the right height in lowest position of the screen.

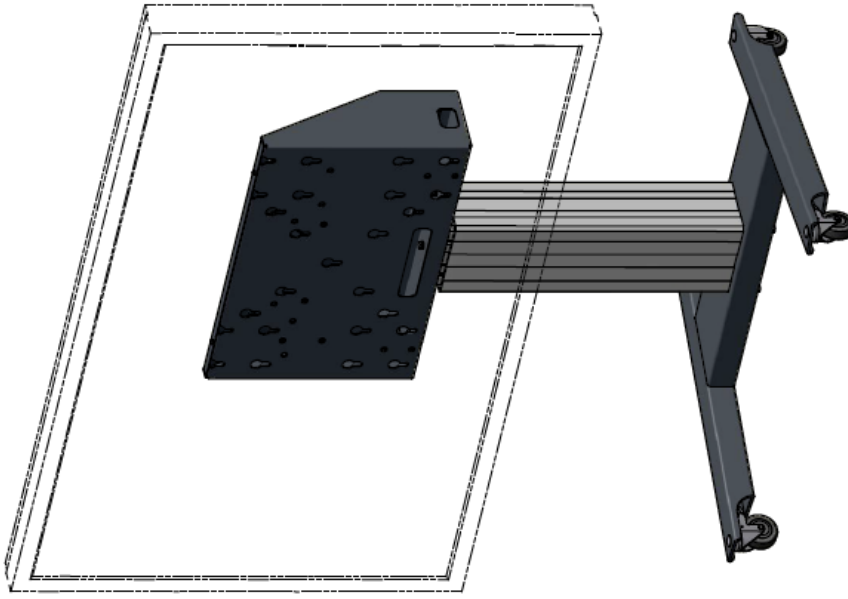
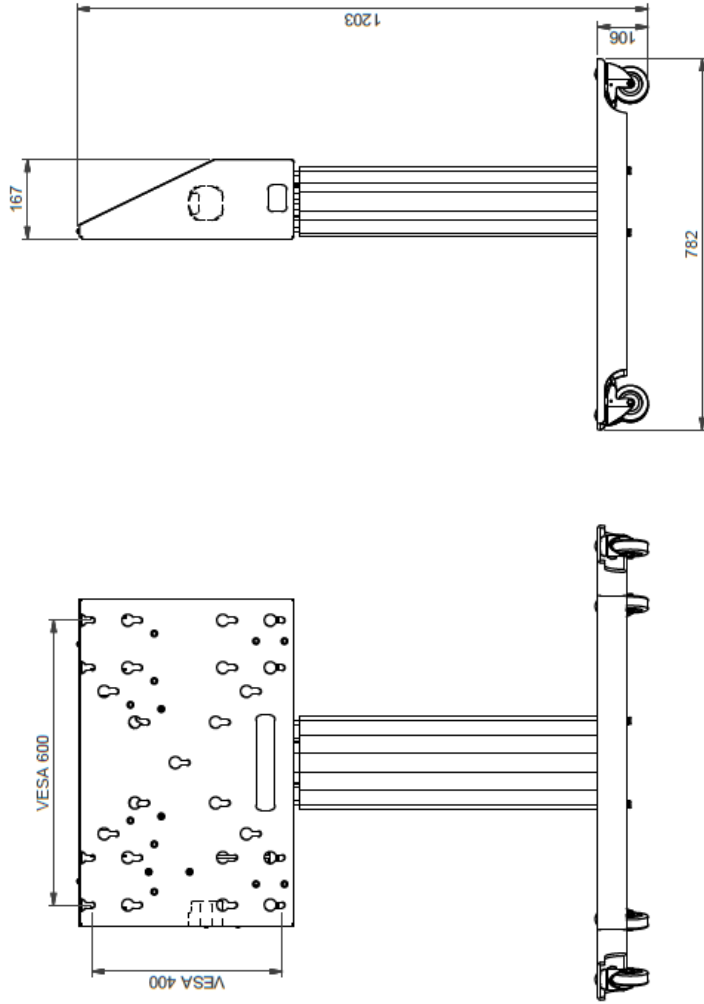
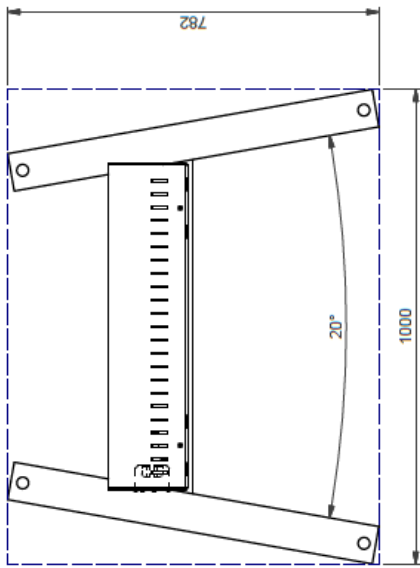

NOTE: All dimensions are ±..., in mm and subject to change

© COPYRIGHT AUDIPACK
This print and the information shown
thereon, is the property of
AUDIPACK.
It may not be delivered to others nor
reproduced for general circulation
without the written consent of the
AUDIPACK engineering department.



AUDIPACK
Industriestraat 2-4
2751 GT Moerkapelle
the Netherlands
Tel: +31(0)796931671
Fax: +31(0)796933115
www.audipack.com

PRESENTATION
FSW-T150V6_presentation

TOUCH TROLLEY

Dimensions are indications, not to be used for any preparations. No rights can be derived from the above dimensions.

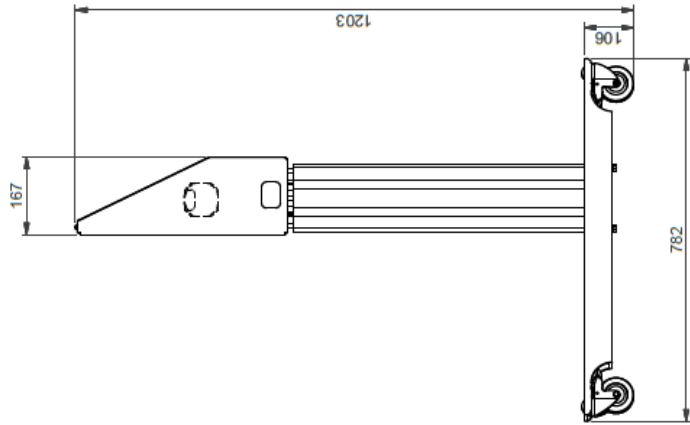
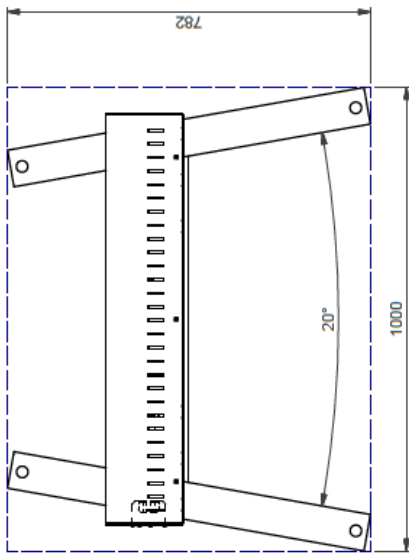

Max.
150 kg

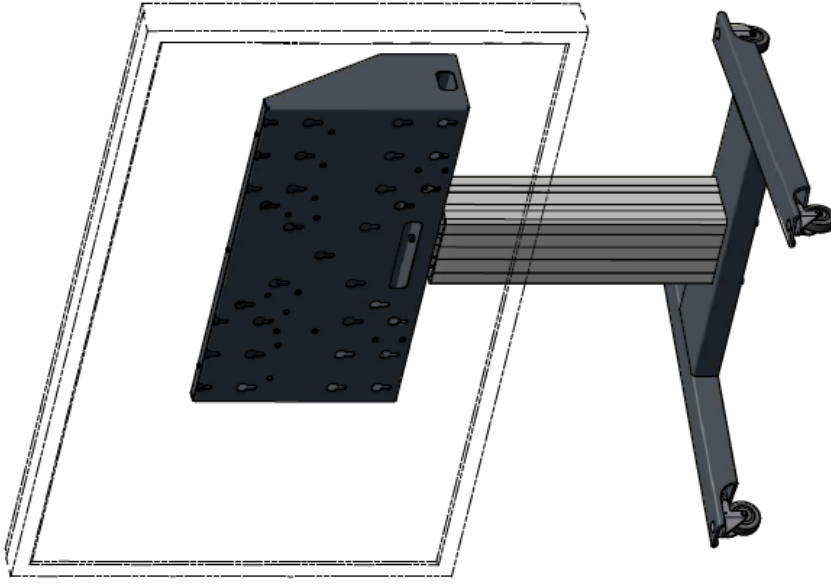

NOTE: All dimensions are ±... in mm and subject to change

© COPYRIGHT AUDIPACK
This print and the information shown
thereon, is the property of
AUDIPACK.
It may not be delivered to others nor
reproduced for general circulation
without the written consent of the
AUDIPACK engineering department.



AUDIPACK
Industriestraat 2-4
2751 GT Moerkapelle
the Netherlands
Tel: +31(0)799931671
Fax: +31(0)79993115
www.audipack.com

PRESENTATION
FSW-T150V8_presentation

TOUCH TROLLEY

Dimensions are indications, not to be used for any preparations. No rights can be derived from the above dimensions.

Audipack's general conditions of sales and delivery apply to all of Audipack's deliveries. These conditions can be downloaded from Audipack's website, www.audipack.com, or will be sent by post on request.

Audipack liefert ausschließlich unter die allgemeine Verkauf- und Lieferungsbedingungen von Audipack. Diese Bedingungen sind zum downloaden verfügbar auf die Webseite von Audipack, www.audipack.com, oder werden Ihnen auf Anfrage per Post gesendet.

Alle leveringen geschieden uitsluitend volgens de Algemene Verkoop- en Leveringsvoorwaarden van Audipack. Een afschrift hiervan kunt u downloaden van de website van Audipack, www.audipack.com, of wordt u op aanvraag gestuurd per post.

Les conditions de vente et de livraison de Audipack s'appliquent à tous les livraisons de Audipack. Cette conditions sont disponible sur le site internet de Audipack, www.audipack.com, où seront envoyé par poste sur demande.

AUDIPACK

Industriestraat 2-4
2751 GT Moerkapelle
the Netherlands

Tel: +31(0)795931671
Fax: +31(0)795933115
Email: audipack@audipack.com

www.audipack.com

Audipack reserves the right to make changes in specifications and other information contained in this document without prior written notice. The information provided herein is subject to change without notice. In no event shall Audipack be liable for any incidental, special, indirect, or consequential damages whatsoever, including but not limited to lost profits, arising out of or related to this manual or the information contained herein, even if Audipack has been advised of, known, or should have known, the possibility of such damages.