

## How to re-adjust the motor end limits of a Ceiling lift.

General for all Audipack ceiling lift systems.

### **Explanation:**

The Audipack ceiling lift systems have internal and external end switches.  
The motor itself has two internal adjustable end points; these are factory set and normally **not to be used** for the customer.  
In our factory both end stops are set, and the external switches (with the turning knob) are for the customer to use.

When a lift has a faulty end factory setting on the motor revolutions, this must be set again.

### **Recognize first for the 1070 and 1090 ceiling lift:**

On top of the lift at one end of the motor (not the side of the bearing) is a yellow plastic part that covers two buttons; a yellow and a white button.

Also see the external switches to set the lift positions (on each side of the lift)

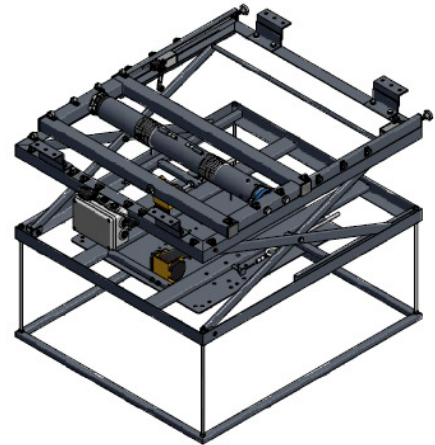

Motor limits

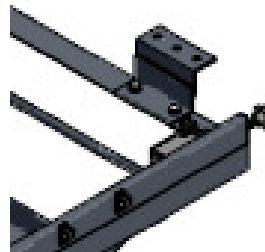

External switches

### **Read and understand, do not touch yet:**

Each color represents the rotation direction of the motor.

By pushing in the buttons the settings are removed.

By pushing again and letting the button to come out (pop out) 1 switch (responsible for the rotation direction)- on the right lift position; the end position of the lift can be set.

**To work as safe as possible please follow the next steps.**

1.  
Lower the lift to aprox 250 mm down **by using the print switches** on the pcb.  
If the lift runs automatically after a single push, the automatic activation must be turned of on the lift pcb.  
It advisable to disconnect the control cable of your remote system.

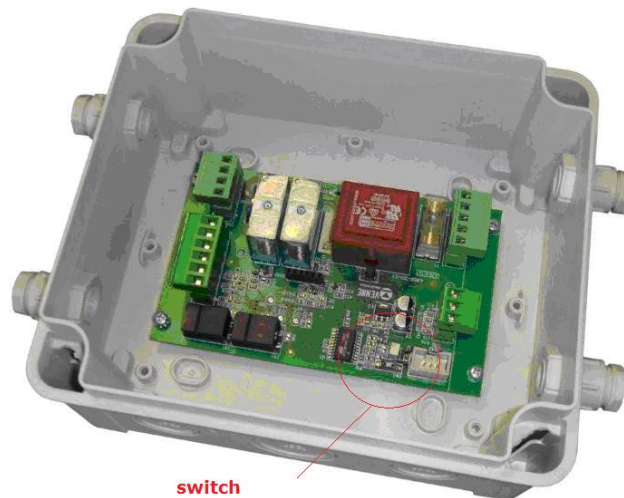

**Warning:**

The motor in the lift is very strong and can pull a 260 Kg!  
That means if the motor is winding up to far, the construction of the lift may damage.  
To prevent this and first to understand the mechanism you will set the external switches to a safe position.

2.  
Turn the external UP switch left wise in a way that the switching lever is moved away from the back of the lift (aprox 40 mm)
3.  
Turn the external DOWN switch right wise; the descent of the lift will be limited.  
Make sure that the switching lever is 150 mm removed from the -motor frame (or end limit).  
With these safety adjustments it is " safe" to push in the yellow and white button.  
Now the motor end stops are away.

4. Lower the lift and reset the external switch until you have almost reached the mechanical end of the lift. Do the same thing for the UP position. Be aware of the minimum construction height of the lift. See the below table for indications of dimensions.

**The first dimension represents the vertical descend, second dimension after the / is the build-in height.**

P1983	P1984
1070	1090
W 770 x D 900	W 815 x D 1000
W 770 x D 1017	W 815 x D 1117
1 stroke: 700 / 150	1 stroke: 700 / 170
2 stroke: 1400 / 210	2 stroke: 1400 / 230
3 stroke: 2100 / 235	3 stroke: 2100 / 255
4 stroke: 2800 / 265	4 stroke: 2800 / 285
5 stroke: 3500 / 295	5 stroke: 3500 / 315
6 stroke: 4200 / 325	6 stroke: 4200 / 345
7 stroke: 4900 / 355	7 stroke: 4900 / 375
8 stroke: 5600 / 400	8 stroke: 5600 / 420

When both end stops are set, cover the buttons again with the yellow hood.

**Take no risk, call us any time for technical consult, even on location.**

**Phone +31 79 5931671**

## How to re-adjust the motor end limits of a 2040-4050 and 1060 Ceiling lift.



© copyright Audipack



© copyright Audipack

### **Recognize first for the 2040 model range and the 1060 ceiling lift:**

On top of the lift at one end of the motor (not the side of the bearing) is a yellow plastic part or seal that covers two screws; a yellow and a white HEX screw.

Also see the external switches to set the lift positions (on each side of the lift)



Motor limits



External switches

### **Read and understand, do not touch yet:**

Each color represents the rotation direction of the motor.

By turning the buttons the setting are adjustable.

Before setting permanently, first practice on a safe position somewhere in the middle of the lift's descend.

**To work as safe as possible please follow the next steps.**

1.  
Lower the lift to aprox 250 mm down **by using the print switches** on the pcb.  
If the lift runs automatically after a single push, the automatic activation must be turned of on the lift pcb.  
It advisable to disconnect the control cable of your remote system.

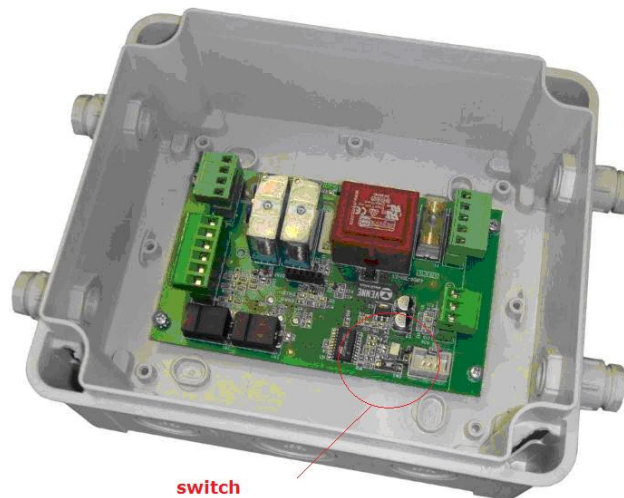

**Warning:**

The motor in the lift is very strong and can pull a 100-200 Kg!  
That means if the motor is winding up to far, the construction of the lift may damage.  
To prevent this and first to understand the mechanism you will set the external switches to a safe position.

2.  
Turn the external UP switch left wise in a way that the switching lever is moved away from the back of the lift (aprox 40 mm)
3.  
Turn the external DOWN switch right wise; the descent of the lift will be limited.  
Make sure that the switching lever is 100-150 mm removed from the bearing bar (or end limit).  
With these safety adjustments it is " safe" to rotate the yellow and white button (HEX).

4.  
Lower the lift and reset the external switch until you have almost reached the mechanical end of the lift.  
When the lift stops before reaching the end position of the lift rotate the HEX screw in the + direction to allow the motor rotate more. Make these adjustment is small steps!  
Do the same thing for the UP position.

Be aware of the minimum construction height of the lift.  
See the below table for indications of dimensions.

**Due to the many models, please refer to the Audipack catalogue for the right build-in dimensions and the maximum lift descend.**

**Take no risk, call us any time for technical consult, even on location.**

**Phone +31 79 5931671**